

THIS DOCUMENT IS SUBJECT TO CHANGE WITHOUT NOTICE. IT IS CONFIDENTIAL AND A PROPERTY OF Amphenol LTW. DISCLOSURE TO THIRD PARTY HAS TO BE AUTHORIZED BY Amphenol LTW.

REV.	ECN NO.	DATE	SIGN	DESCRIPTION
A	Initial Released	2019/11/08	Brady	Initial Released
B	C210429	2021/03/26	Vicky	$\triangle B$ X3

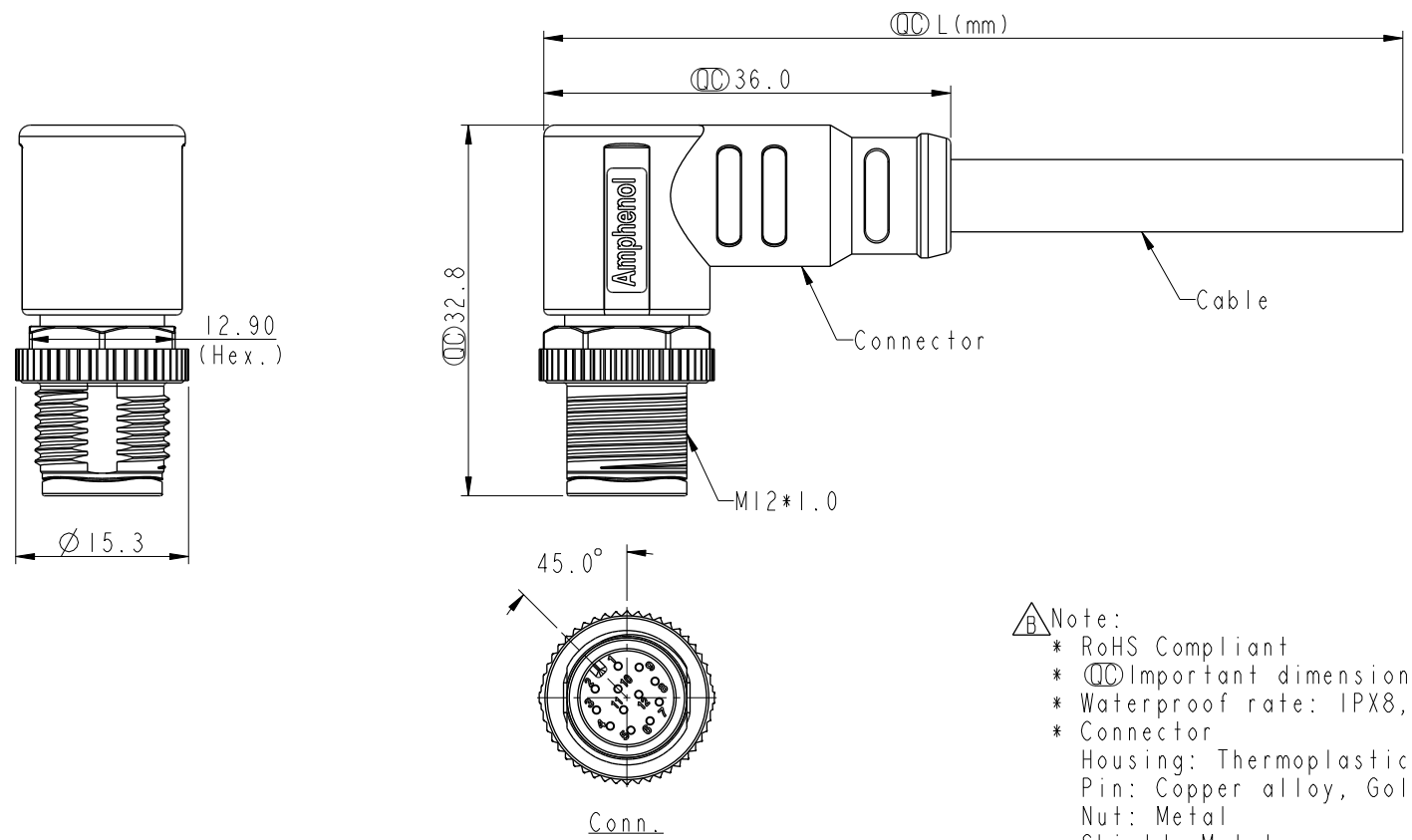

- $\triangle B$ Note:
- * RoHS Compliant
 - * CC Important dimension
 - * Waterproof rate: IPX8, mated 1m/24h
 - * Connector
 - Housing: Thermoplastic, Black
 - Pin: Copper alloy, Gold plated
 - Nut: Metal
 - Shield: Metal
 - Outer mold: Thermoplastic, Black
 - * Cable: UL20549, Shield, PU Jacket, Black
 - * Cable length tolerance:
 - 1M < L \leq 3M: +100/-0 mm
 - 3M < L \leq 5M: +150/-0 mm
 - 5M < L \leq 10M: \pm 100 mm
 - 10M < L \leq 20M: \pm 200 mm
 - 20M < L \leq 30M: \pm 300 mm
 - 30M < L \leq 99M: \pm 500 mm

UNIT: mm			TITLE N SEN, M12 A -SHLD, SCREW CABLE W/O SR, M, M, MOLDING		
TOLERANCE	$\pm 0.5\text{mm}$		SCALE 3:2	SIZE A4	SHEET 1 OF 2
REV. B	WC-REV. A.5	CC : Inspection item			

Amphenol LTW
安費諾亮泰企業股份有限公司

ITEM NO.	DRAWN BY Brady Chung	DATE 2019/11/08
DWG NO. MSAS-XXBMMM-SR8BXX	CHECKED BY Jane Wang	DATE 2019/11/08
CUSTOMER ALTW	APPROVED BY Neo Tsai	DATE 2019/11/08

THIS DOCUMENT IS SUBJECT TO CHANGE WITHOUT NOTICE. IT IS CONFIDENTIAL AND A PROPERTY OF Amphenol LTW. DISCLOSURE TO THIRD PARTY HAS TO BE AUTHORIZED BY Amphenol LTW.

12P	6.4	26	MSAS-12BMMM-SR8BXX
8P	5.8	24	MSAS-08BMMM-SR8BXX
5P	5.7	22	MSAS-05BMMM-SR8BXX
Contacts	Cable OD	AWG	Item No.

△B
 MSAS-XXBFFM-SR8BXX
 XX: No. Of Pin
 XX: 01~99Meters
 01: 01Meter
 02: 02Meters
 .
 99: 99Meters

Pin Out	Shield	Braid	Shield	Braid	Shield	Braid	Shield	Braid	Shield	Braid	Shield	Braid	
5	--		5	--	5	Gray	灰	5	--		5	Gray	灰
4	Black	黑	4	Black	4	Black	黑	4	Yellow	黃	4	Yellow	黃
3	Blue	藍	3	Blue	3	Blue	藍	3	Green	綠	3	Green	綠
2	--		2	White	2	White	白	2	Brown	棕	2	Brown	棕
1	Brown	棕	1	Brown	1	Brown	棕	1	White	白	1	White	白
Pin #	Wire		Pin #	Wire	Pin #	Wire		Pin #	Wire		Pin #	Wire	

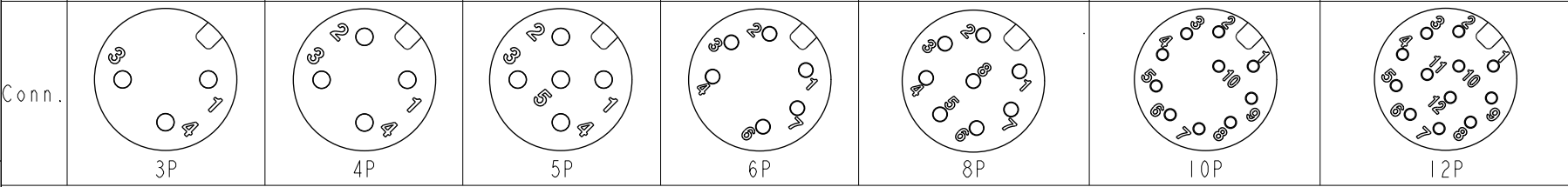

Pin Assignments Front View

UNIT:mm		TITLE N SEN, M12 A -SHLD, SCREW CABLE W/O SR, M, M, MOLDING	<h1>Amphenol LTW</h1> <p>安費諾亮泰企業股份有限公司</p>		ITEM NO	DRAWN BY Brady Chung	DATE 2019/11/08
TOLERANCE ±0.5mm		SCALE 3:2			SIZE A4	SHEET 2 OF 2	DWG NO MSAS-XXBMMM-SR8BXX
		REV. B	WC-REV. A.5	QC: Inspection item	CUSTOMER ALTW	APPROVED BY Neo Tsai	DATE 2019/11/08