

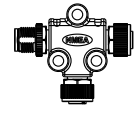

THIS DOCUMENT IS SUBJECT TO CHANGE WITHOUT NOTICE. IT IS CONFIDENTIAL AND A PROPERTY OF Amphenol LTW. DISCLOSURE TO THIRD PARTY HAS TO BE AUTHORIZED BY Amphenol LTW.

REV.	ECN NO.	DATE	SIGN	DESCRIPTION
A	Initial Release	2017-06-28	Fisher Wang	Initial Release
B	LEN1781511	2017-08-17	Frank Deng	Update Note
C	LEN1790001	2017-08-25	Frank Deng	Update PN of Terminator

Basic	① HPC-050505-FMF-TS001	3 Tee Adaptor 2Pcs	
	② HMCP-05BFFT-SL8001 △	Female Terminator 1Pcs	
	③ HMCP-05BMMT-SL8001 △	Male Terminator 1Pcs	
	⑤ HPC-050500-FM0-TSA02	T Cable, 2M 1Pcs	
	④ HPC-000505-0MF-CSA02	Drop Cable Cable Length=2M, 1Pcs	

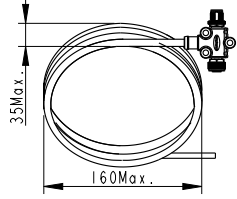
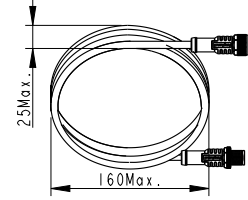
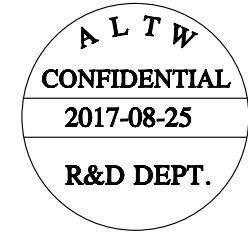

- △ Note:
- * 3 Tee Adaptor: 2PCS
 - * Female Terminator 1PCS
 - * Male Terminator :1PCS
 - * T-Cable, cable length 2m, 1pcs
 - * 2 Ends Cable, cable length 2m, 1PCS
 - * All connector put into the blister tray
 - * 注意繞線尺寸需符合圖面要求, 否則會影響產品裝入彩盒.
 - * 5pcs blister tray /Carton
 - * Net weight: 1.7kg / Carton
 - * Gross weight: 3.9Kg / Carton

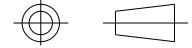
UNIT:mm	
TOLERANCE	

TITLE NMEA2000 Starter Kit Plastic, Basic Type			
SCALE Free	SIZE A4	SHEET 1 OF 2	
REV. C	WC-REV. A.1	QC: Inspection item	

Amphenol LTW
安費諾亮泰企業股份有限公司

ITEM NO HPC-B-001	DRAWN BY Frank Deng	DATE 2017-08-25
DWG NO HPC-B-001	CHECKED BY Fisher Wang	DATE 2017-08-25
CUSTOMER ALTW	APPROVED BY Kevin Hu	DATE 2017-08-25

THIS DOCUMENT IS SUBJECT TO CHANGE WITHOUT NOTICE. IT IS CONFIDENTIAL AND A PROPERTY OF Amphenol LTW. DISCLOSURE TO THIRD PARTY HAS TO BE AUTHORIZED BY Amphenol LTW.

Package:

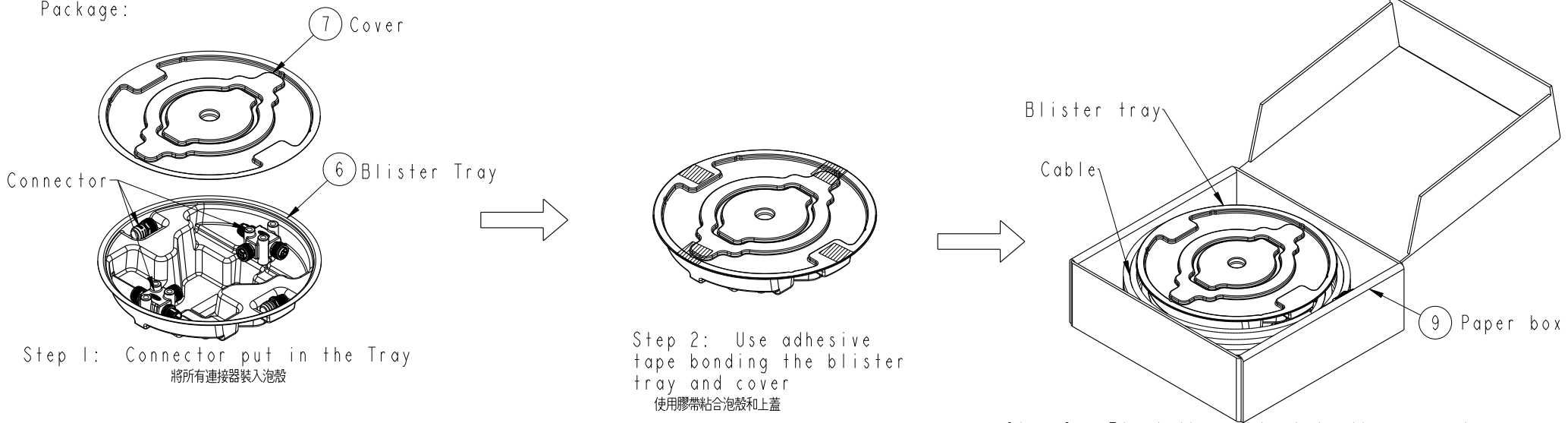

ALTW
CONFIDENTIAL
2017-08-25
R&D DEPT.

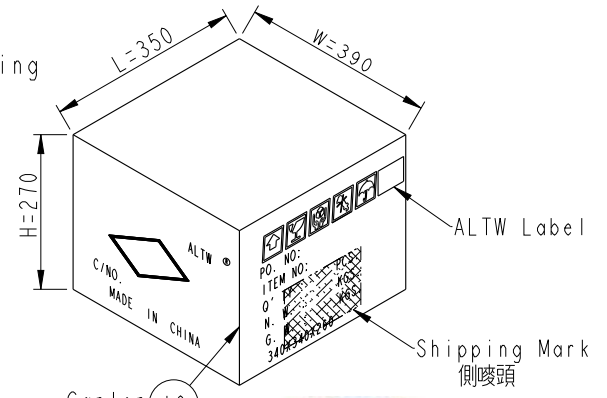
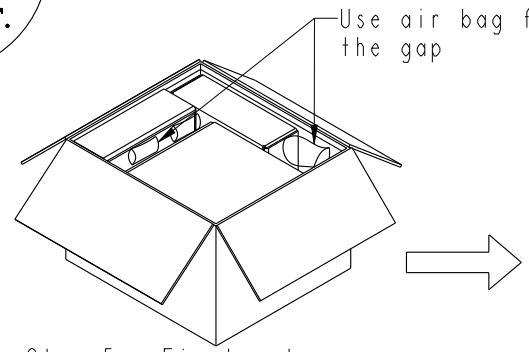
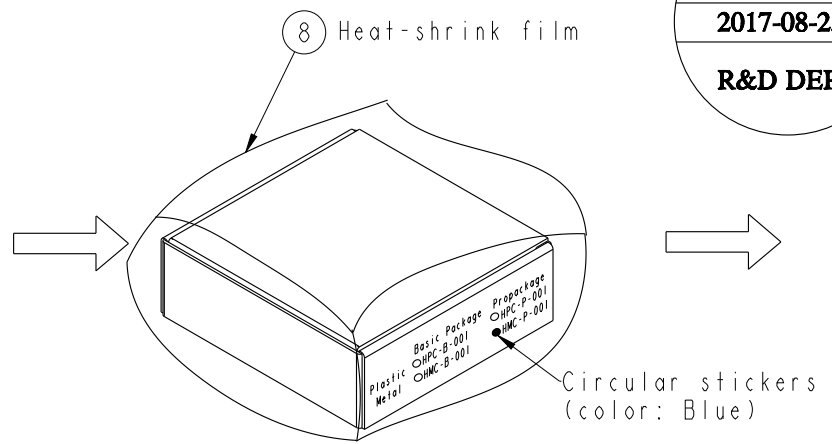

ALTW
DCC. DEPT.
CONFIDENTIAL
2017.09.04
ISSUED

UNIT: mm		
TOLERANCE		

TITLE NMEA2000 Starter Kit Plastic, Basic Type			
SCALE Free	SIZE A4	SHEET 2 OF 2	
REV. C	WC-REV. A.1	QC: Inspection item	

Amphenol LTW
安費諾亮泰企業股份有限公司

ITEM NO HPC-B-001	DRAWN BY Frank Deng	DATE 2017-08-25
DWG NO HPC-B-001	CHECKED BY Fisher Wang	DATE 2017-08-25
CUSTOMER ALTW	APPROVED BY Kevin Hu	DATE 2017-08-25